



Design of Fundamental Power Coupler of 5 Cell Elliptical SRF Cavity Using CST Microwave Studio

Rajdip Das^{1*} and B. N. Biswas¹

¹*Supreme Knowledge Foundation Group of Institutions, Sir J. C. Bose School of Engineering, Mankundu, Hooghly, West Bengal 712139, India.*

Authors' contributions

This work was carried out in collaboration between both authors. Both authors read and approved the final manuscript.

Article Information

DOI: 10.9734/JERR/2020/v19i117221

Editor(s):

(1) Dr. Tian-Quan Yun, South China University of Technology, China.

Reviewers:

(1) Jalal Jamal Hamad Ameen, University of Salahaddin, Iraq.

(2) Stefan Iulian, University of Craiova, Romania.

Complete Peer review History: <http://www.sdiarticle4.com/review-history/62612>

Original Research Article

Received 29 August 2020
Accepted 04 November 2020
Published 23 November 2020

ABSTRACT

A 5 cell elliptical cavity prototype has been build to accelerate the 100 MeV high beam of protons [1]. For cavity = $0.61 \beta g$ at 650 MHz in which the cavity structure is optimized by using the code from SUPERFISH [2]. The Q value of the cavity measured is 0.61×10^9 for 4.2 K. In the frequency range 2 – 5 GHz with CST MICROWAVE STUDIO [3]. It has been designed taking into account the advantages of both the waveguide type and coaxial type coupler This paper explains the current design of the cavity with a different angle of aperture and wall which have better mechanical stability and flatness, consisting of facilities for surface processing and less loss of beam. In this paper, the fundamental power coupler of a 5-cell 650MHz elliptical SRF cavity has been designed using CST MICROWAVE STUDIO. Here we have considered the ceramic window matching and co-axial to rectangular waveguide matching for the power coupler.

Keywords: *Cavity Design; ceramic window matching; rectangular waveguide matching; fundamental power couplers (FPC); higher-order mode couplers (HOM).*

*Corresponding author: Email: rdrajdipdas1@gmail.com;

1. INTRODUCTION

In the last three decades, superconducting accelerator technology has allowed superconducting RF (SRF) [4] cavities with accelerating gradients above 30 MV / m, just within a factor of two elliptic high-to-niobiums theoretical limits. The gradients of the cavity also increased to accelerate the beam. The power handling specifications of the couplers for modern machinery currents for moving power has dramatically grown in and out of these cavities. Attaching the requirements like incorporation, high durability, atmospheric bridging, liquid helium temperatures, low specifications heat leak from cryogenics, fair costs and serious cavity protection from the dynamic existence of the underlying problems of engineering and physics design are going to be clear. RF couplers are the assembly of hardware and parts. In a general sense, a resonating accelerating cavity is required to couple RF energy. Fundamental Power Couplers (FPC) conveys energy to a cavity, and HOM couplers are used to collect the power from FPC or dissipate the radiative excitation of the cavity by the RF energy present in the cavity. These devices have been followed by technological developments, and have set the speed times for the SRF cavity applications. The superconducting cavity power couplers need to handle megawatts of power up to the strength covering 300-2000 MHz frequencies and 1-100 % service factors, they must be achieved when appeasing several and sometimes contradictory constraints at the same time. Besides, if a coupler does not achieve its performance goals and scientific output, the facility is being corrupted, and the adverse effects are severe. The possible fallout will be appreciable by system builders, financing organizations, and the general population. Proper diligence must be applied to the RF coupler design process for these reasons.

The technical spectrum of SRF accelerators is another complication, broad and varied approaches to the RF are such that no coupler is suitable for all applications. At best, one can follow general guidelines. At worst, the paths that lead all the way, and a fog rolls in. To support the SRF society in their need this guide is available to help designers to achieve a simpler, more efficient RF coupler technology. Although the challenges involved are more qualitative, what are the problems and what are they? Others in the field have used methods and strategies and

what principles and strategies operating methods. The reader is encouraged to review two additional information articles [5,6].

In this paper the authors have proposed a new fundamental power coupler of SRF cavity of 650 MHz 5-cell circular depressions with mathematical speed factors $\beta_G = 0.61$ have been proposed. The depressions are needed to work in super fluid helium at a temperature of around 2K, with a quickening angle (E_{acc}) of 17 MV/m. The cell shape has been intended to limit the pinnacle surface attractive (B_{peak}) and pinnacle surface electric field (E_{peak}), to accomplish the necessary inclination and least field discharge, and to limit the impact of multipacting also, to expand R/Q and mathematical factor (G) to have less RF power scattering in the hole divider and more modest heat load on the cryogenic framework. RF plan of the depression has been done utilizing 2-D SUPERFISH and 3-D CST Microwave Studio. A circuit has been designed and fabricated for power transmission through the coupler. Finally, the carried out to study the accelerating mode and the effective impedance of the transverse HOM's which is followed by the variation of return loss with the doorknob height. The proposed power coupler was found to be better than the existing couplers.

The rest of the paper is organized as follows. The next section describes the theoretical background survey associated with the fundamental power couplers (FPC) and higher-order mode couplers (HOM) in brief along with the figure of merits of the cavity performance in detail. The design methodologies of the proposed power coupler are discussed in section 4. The results obtained from the experiments are presented and discussed in section 5. Finally, the paper is concluded in the section

2. BACKGROUND SURVEY

There can be two kinds of RF power couplers on a given superconducting quickening agent. The principal power coupler is utilized to energize the resounding structure to develop and put away energy in the principal speeding up method of the depression. Higher request mode couplers are utilized to remove RF power from the depression at frequencies over the central, consequently damping the modes and diminishing their capacity to corrupt the pillar quality and increment cryogenic heap of the framework.

2.1 Fundamental Power Couplers (FPC)

The FPC is utilized to convey RF energy to the cavity at the crucial recurrence of the quickening agent framework. While this is near the full recurrence of the cavity, it isn't indistinguishable. Contingent upon the degree of detuning due to microphonics, shaft stacking, and the simultaneous stage set point, an FPC should proficiently send control over a scope of RF frequencies. Luckily for most applications, the transmission capacity of these detuning impacts is unassuming, and most RF transmission line frameworks and segments can without much of a stretch oblige it. As the misfortunes in a superconducting depression are so low, the measure of RF influences the coupler necessities to convey is in the scope of tens to several kilowatts in either nonstop wave (CW) or beat activity. FPCs will in general be founded on either waveguide or coaxial RF transmission lines.

2.2 Higher-Order Mode Couplers (HOM)

HOM are gadgets that eliminate or disseminate undesirable, higher recurrence RF energy in a cavity. There are two kinds of HOM couplers – those that concentrate and transport HOM capacity to a dissipative burden mounted external the depression vacuum, and those that have the dissipative medium adjoining with the cavity vacuum. The significant contrast between a HOM and a basic force coupler is the FPC requirements to effectively send RF power at the principal quickening agent recurrence f_0 , where a HOM coupler needs to effectively communicate just frequencies higher than f_0 . A HOM coupler that separates the essential force of depression is a major issue.

3. FIGURE OF MERITS FOR CAVITY PERFORMANCE

The primary figures of legitimacy for a quickening structure are characterized and examined in [7]. These are: RF recurrence, quickening voltage (V_c), quickening field (E_{acc}), top surface electric field (E_{pk}), top surface attractive field (H_{pk}), surface opposition (R_s), calculation factor (G), disseminated power (P_c), put away energy (U), Q esteem, mathematical shunt impedance (R_{sh}/Q_0 , regularly referenced as R/Q for short), cell-to-cell coupling for multi-cell structures, Lorentz-Force (LF) detuning coefficient, input power needed for pillar power (P_b), coupling quality of information coupler (Q_{ext}), higher-request mode frequencies, and shunt impedances. We present a top to a

bottom conversation of a few significant figures of legitimacy. The pit quickening voltage V_c is the proportion of the most extreme energy gain that a molecule moving along the cavity hub can accomplish to the charge of that molecule. The quickening inclination is characterized as the proportion of the quickening voltage per cell V_c to the cell length. As the ideal length of the depression cells is normally $\beta\lambda/2$, the quickening inclination is given in equation 1.

$$E_{acc} = \frac{V_c}{\beta\lambda/2}. \quad (1)$$

The equation 2 describes the RF power dispersal in a cavity divider is portrayed by the quality factor Q_0 , which discloses to us the number of RF cycles (duplicated by 2π) are needed to disseminate the energy U put away in the cavity:

$$Q_0 = \frac{\omega_0 U}{P_c} = \frac{\omega_0 \mu \int_V |\mathbf{H}(\mathbf{r})|^2 dV}{\oint_A R_s |\mathbf{H}(\mathbf{r})|^2 dA}. \quad (2)$$

Whereas P_c is the RF power scattered in the cavity. The RF attractive field $H(r)$ in equation 3 describes the energized eigenmode with precise recurrence $\omega_0 = 2\pi f_0$ is coordinated over the depression volume V and surface A . The surface resistivity R_s measures the RF power and relies just upon the recurrence and natural material properties. It remains the main term in the recipe that is the material ward, making it advantageous to compose the quality factor as:

$$Q_0 = \frac{G}{\langle R_s \rangle}. \quad (3)$$

Where G is the geometric factor. The surface resistivity is a component of the RF attractive field and may thusly change along the depression divider. It must have arrived at the midpoint of over the cavity surface. The calculation factor G is resolved simply by the state of the hole and consequently is valuable for contrasting cavities and various shapes. The cavity's shunt impedance R_{sh} in equation 4 relates the scattered force P_c and the quickening voltage:

$$P_c = \frac{V_c^2}{R_{sh}}. \quad (4)$$

A connected amount is the mathematical shunt impedance R_{sh}/Q_0 , or R/Q , which relies just upon

the cavity's shape. Two key figures of legitimacy are the proportions of the pinnacle surface electric and attractive fields to the quickening angle, E_{pk}/E_{acc} , and B_{pk}/E_{acc} . A high surface electric field can cause field discharge of electrons, in this manner debasing execution. A high surface attractive field may restrict the depression's definitive angle execution by the breakdown of superconductivity, additionally called quench.

heat load of the cryostat, the coupler outer conductor is copper plated, double-walled and cooled by helium gas. Thoroughly and carefully simulations are carried out to optimize the RF structures and heat load, decide cooling design and predict multipacting activities. A prototype was fabricated and a primary power test was accomplished. The calculation of the end cell of the cavity is enhanced to have great field levelness over the five cells.

4. METHODOLOGY

4.1 RF Structure Design

The electromagnetic (EM) plan boundaries [8,9,10] of the upgraded cavity calculation at 2K are summed up in Table 1 and electric field lines for five principal methods of the cavity have appeared in Fig. 1. The main dimensions were rescaled to 650 MHz; some components were redesigned based on the clean assembly procedures and cooling considerations. To minimize coupler's contribution to the overall

Table 1. Cavity EM parameters

Parameters	Values
Frequency	650 MHz
Shape, No. of Cells	Elliptical,5
Geometric Beta(β_G)	0.61
Effective Length= $5 * (\beta_G \lambda / 2)$	704.4mm
Iris Aperture	97mm
E_{peak}/E_{acc}	3
B_{peak}/E_{acc}	4.85
R/Q	297
G	200
Cell-to-Cell coupling, K_{cc}	1.25%

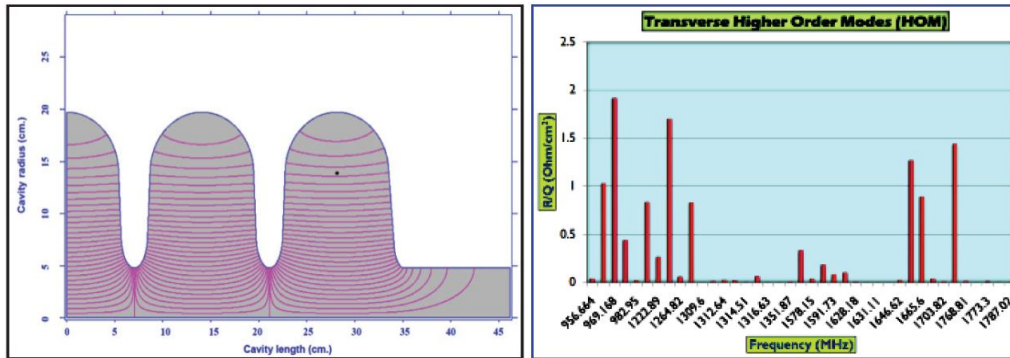

Fig.1. Accelerating mode (π -mode) at 650MHz, and Fig. 2. Effective impedance of transverse HOM's



Fig. 3. Effective impedance of longitudinal HOM's

The 5-cell hole structure has been investigated for cross over and longitudinal higher request modes and their viable impedances have been acquired as low. No caught mode with high powerful impedance (as appeared in Fig. 2 and Fig. 3) is watched for bar current up to a couple of mA.

4.2 Design Considerations

RF frequency matching, power level (peak and average), cavity design, impedance matching has been made individually at the window. The cavity input, and the transition transmission line type are waveguide or coaxial. Here we have used a coaxial power coupler for the window Material selection. The number of windows in our design is only one. To construct the power coupler one coaxial waveguide and a rectangular waveguide are used here.

4.2.1 Circuit Design of Fundamental Power Coupler

The main functions of FPC are to transfer the RF power to the cavity through a dielectric window vacuum barrier and to provide an interface between atmospheric pressure and ultra-high vacuum. It also protects the ultra-clean interior of a superconducting cavity from contamination which prevents any degradation of the cavity performance. There are also some desired properties such as Low RF reflection and transmission losses with the beam loaded cavity, mechanical stability, RF heating, and cooling, etc.

4.3 Design of Fundamental Power Coupler

In this venture, the fundamental coupler of a 5-cell 650MHz circular SRF cavity has been

planned to utilize by CST MICROWAVE STUDIO. Here we have considered the ceramic window matching and co-axial to rectangular waveguide matching for the power coupler.

4.3.1 Ceramic Window Matching

The shape of the ceramic window used here is circular with an inner radius of 6.35 mm. and an outer radius of 36.45 mm. The thickness of the window is 6 mm Fig. 4 is shown below.

It is a 99.5% loss-free Alumina window. For impedance matching during the ceramic window, the inner radius is increased from 6.35 mm. to $22(2 * p_1)$ mm, here p_1 is the inner radius of the ceramic window. The length of the higher inner diameter is d_3 150 mm. This change of the inner diameter d_2 is at 23 mm. away from the ceramic window is shown in Fig. 5. Figs. 6 to 8 represents the graph variation of return loss with the inner radius p_1 , length d_3 , and with the distance d_2 .

4.3.2 Coaxial to rectangular waveguide impedance matching

There is a need of matching the impedance while power is transferred from rectangular waveguide to co-axial. For this type of matching, I have considered the doorknob structure. The short location distance is also considered for impedance matching. The short location distance and the Doorknob height have a significant influence on the Reflection Coefficient and the frequency. The inner and outer radius of the co-axial waveguide is 6.35 mm, and 36.45 mm. The doorknob height in Fig. 9 is 27 mm. and the short location distance in is 103.38 mm. Fig 11 describes the short location distance. The doorknob height is 27 mm. and the short location distance is 103.38 mm. Fig. 10 depicts the practical structure of the R_f power coupler.

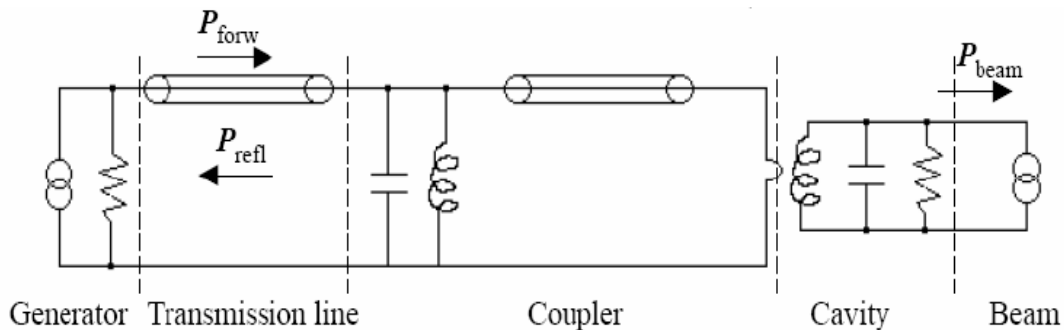

Fig. 3.1. Circuit design of power transmission through coupler

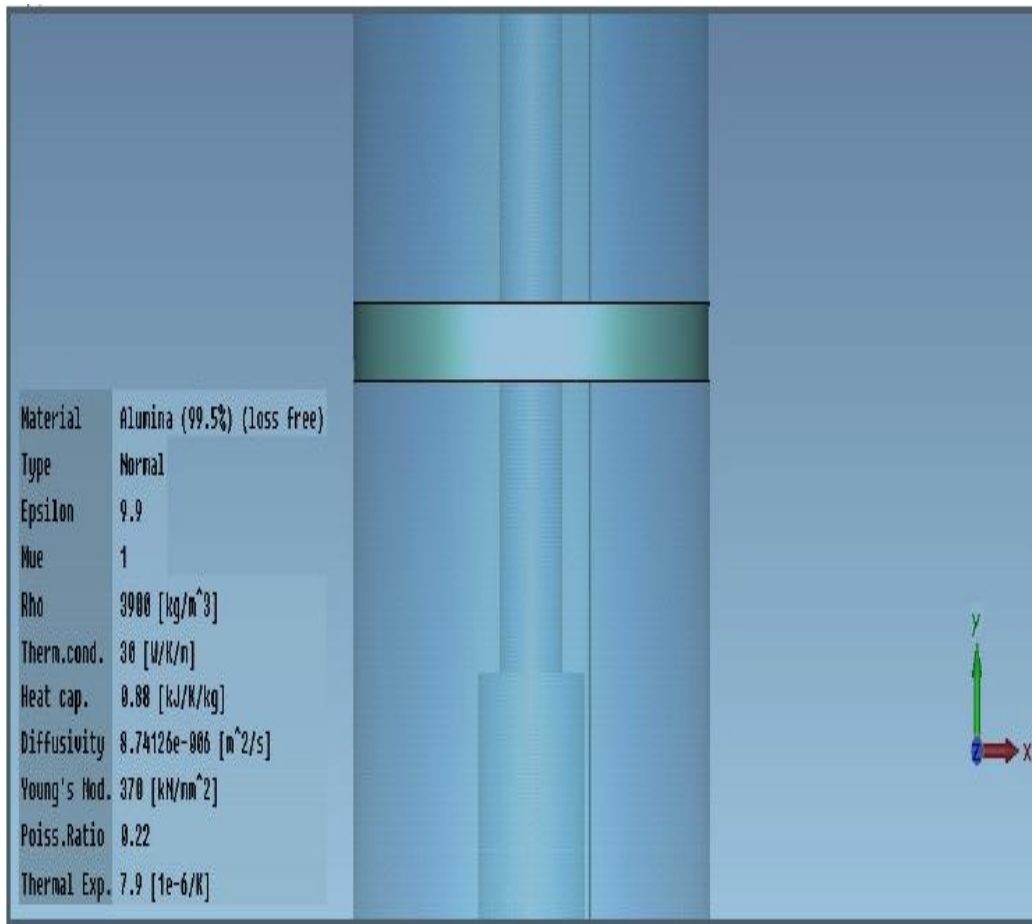

Fig. 4. Ceramic window

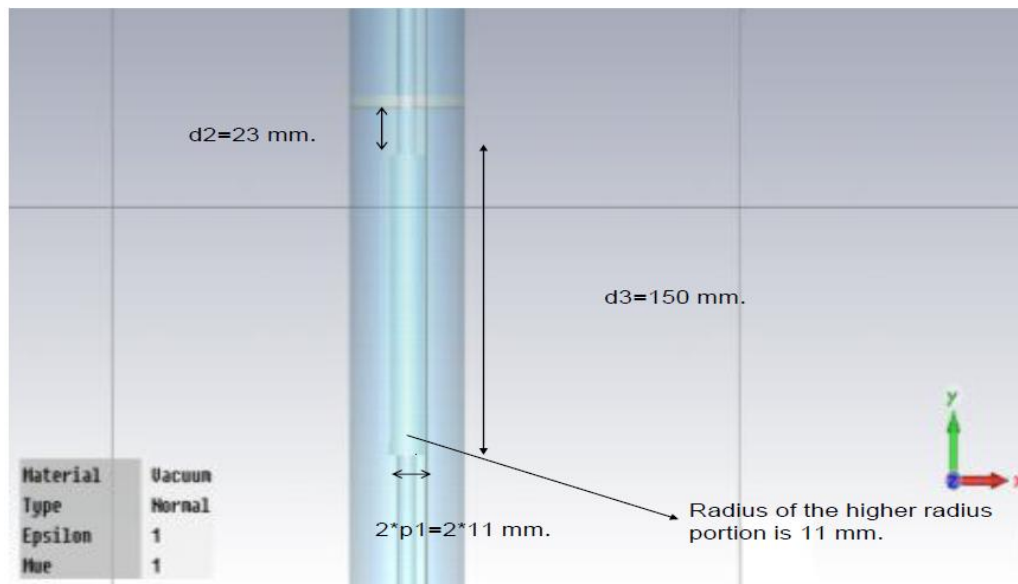

Fig. 5. Impedance Matching during the ceramic window

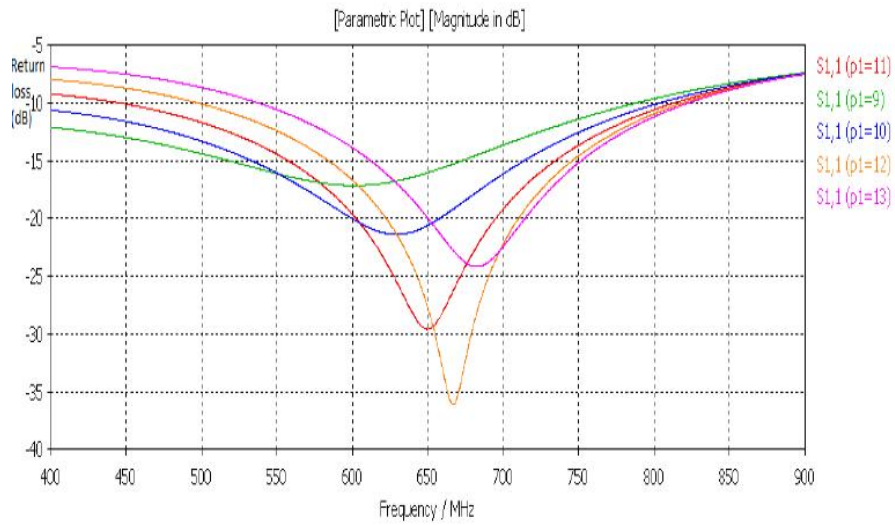

Fig. 6. Variation of return loss (dB) with the inner radius p1

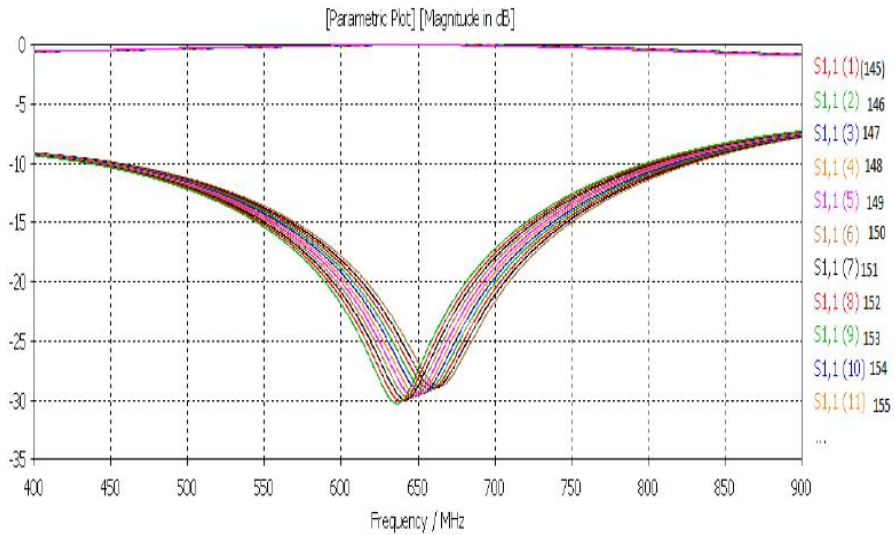

Fig. 7. Variation of return loss (dB) with the length d3

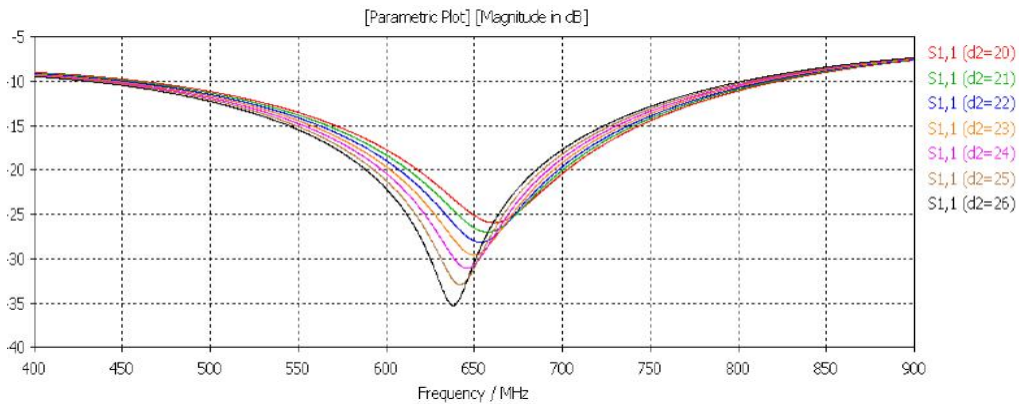

Fig. 8. Variation of return loss (dB) with the distance d2

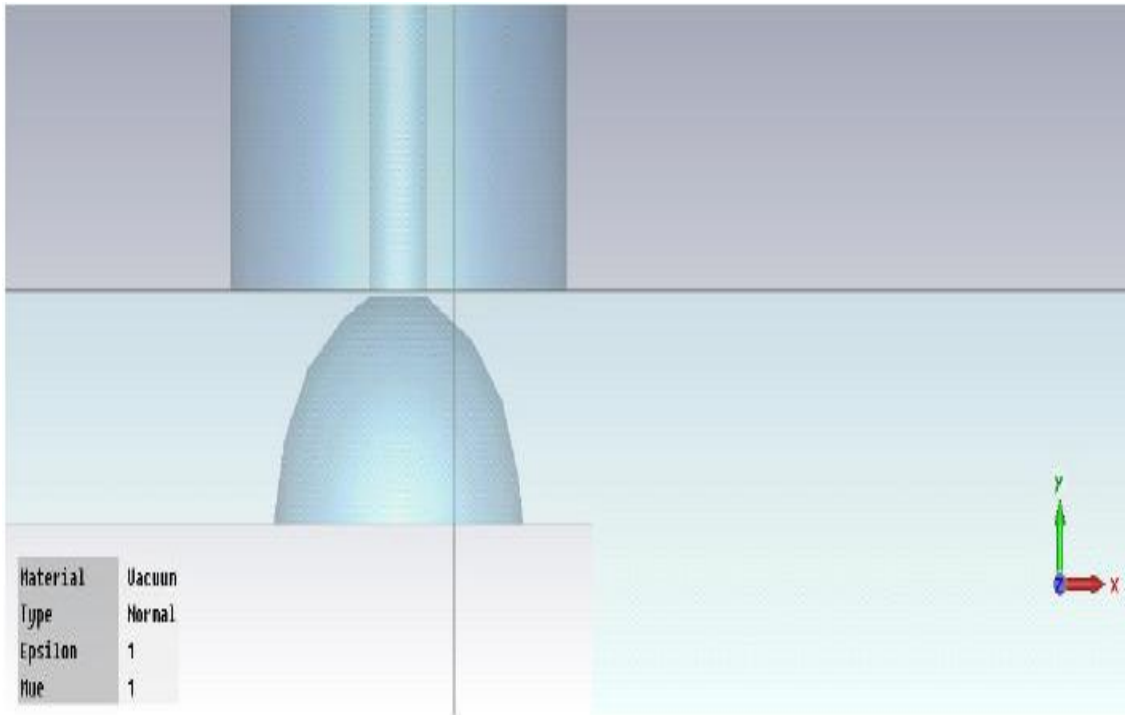

Fig. 9. Doorknob height

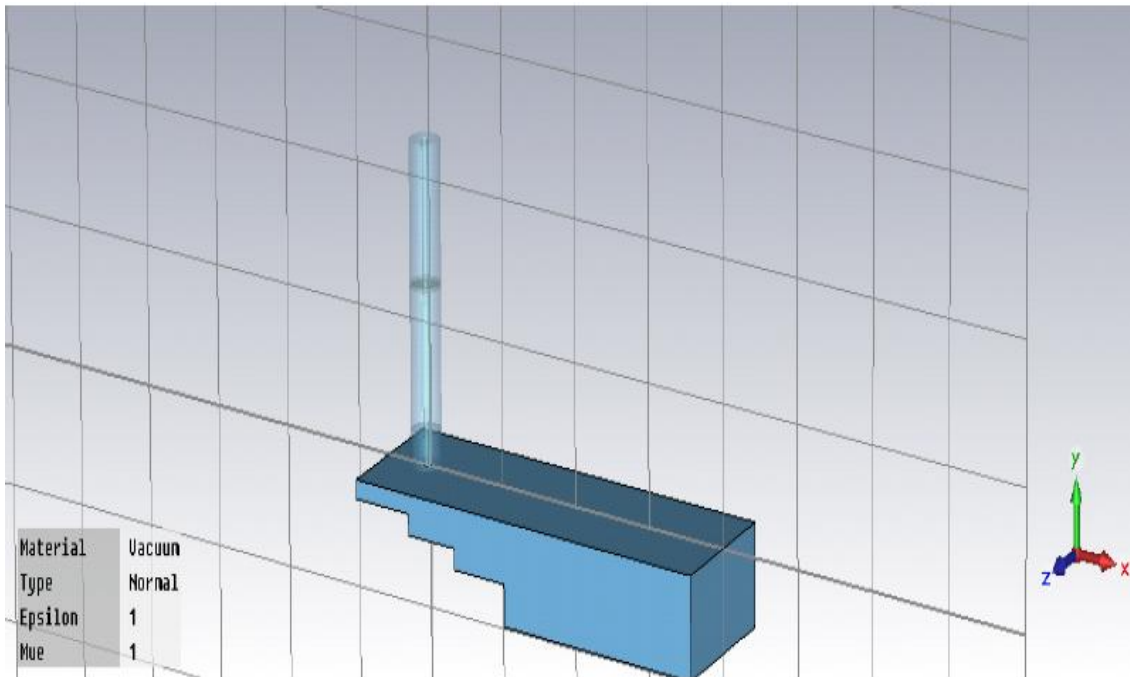

Fig. 10. Practical structure of RF power coupler

A graph has been plotted to check the variation of return loss against the frequency with the doorknob [11] height has been represented in

Fig. 12, and with the short location distance in Fig. 13.

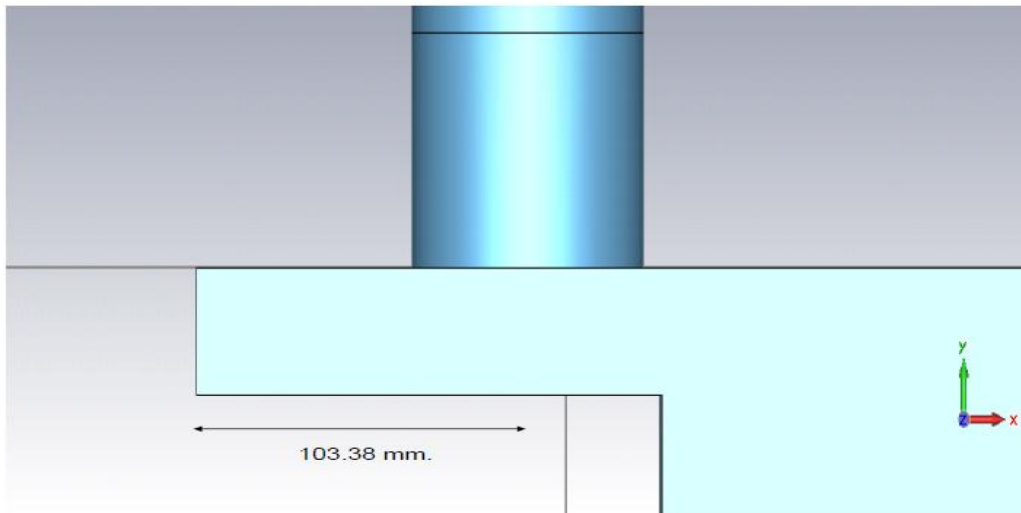

Fig. 11. Short location distance

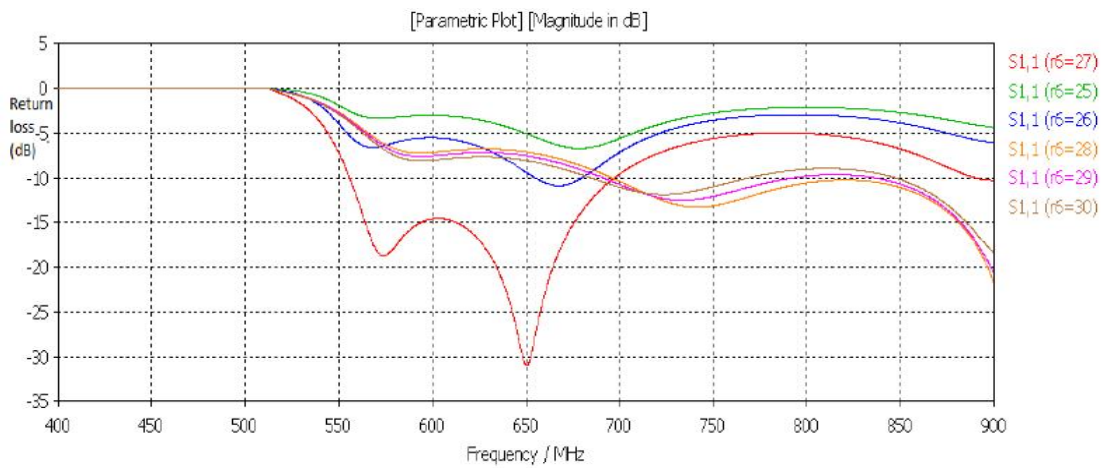

Fig. 12. Variation of return loss (dB) with doorknob height is illustrated in the plot

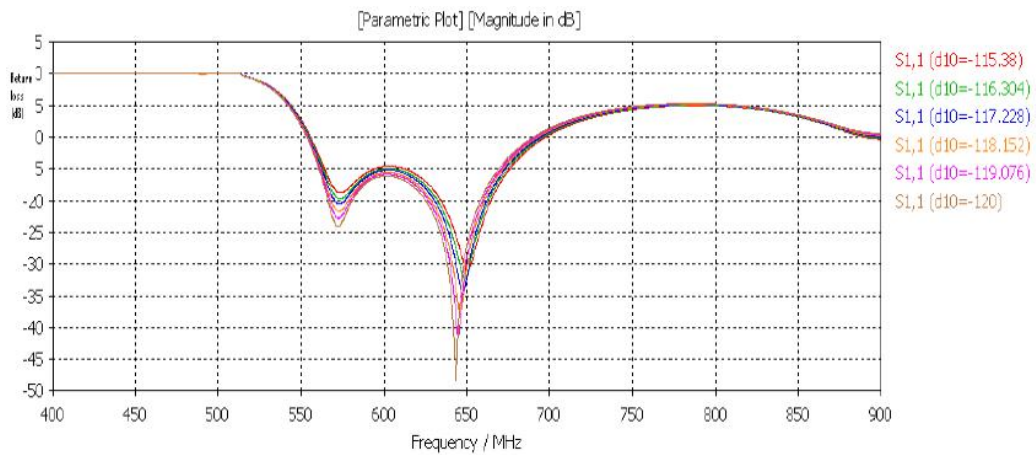

Fig. 13. Variation of return loss (dB) with the short location distance is illustrated in the plot

5. EXPERIMENTAL RESULTS AND DISCUSSIONS

A five-cell copper prototype (as appeared in Fig. 14) has been created utilizing the mid-cell measurements and frequencies of one crucial mode have been estimated (as appeared in Fig. 15) utilizing a dot pull estimation set up effectively created at our lab. The electric field profile along the pivot of the cavity has been obtained for five essential modes. The most noteworthy model is quickening mode or π -mode. The resounding recurrence of π -mode digresses from its reenacted recurrence by 2 MHz and field profile of copper prototype estimated by annoyance procedure utilizing dot

pull estimation set-up is discovered to be non-uniform. As the copper prototype has been manufactured utilizing mid-cell measurements just, the field at end cells is lower than inward cells. Additionally framed copper half cells were not indistinguishable in measurement, with a deviation on the request for 0.6 mm. This is another explanation behind the non-uniform field profile. Hence, we also got the final structure (as appeared in Fig.16) of the RF power coupler by combining the impedance matching of coaxial to the rectangular waveguide and ceramic window matching and plotted a graph as shown in Fig. 17. The Return Loss (dB) at -39.616 dB at 651.4 MHz frequency.

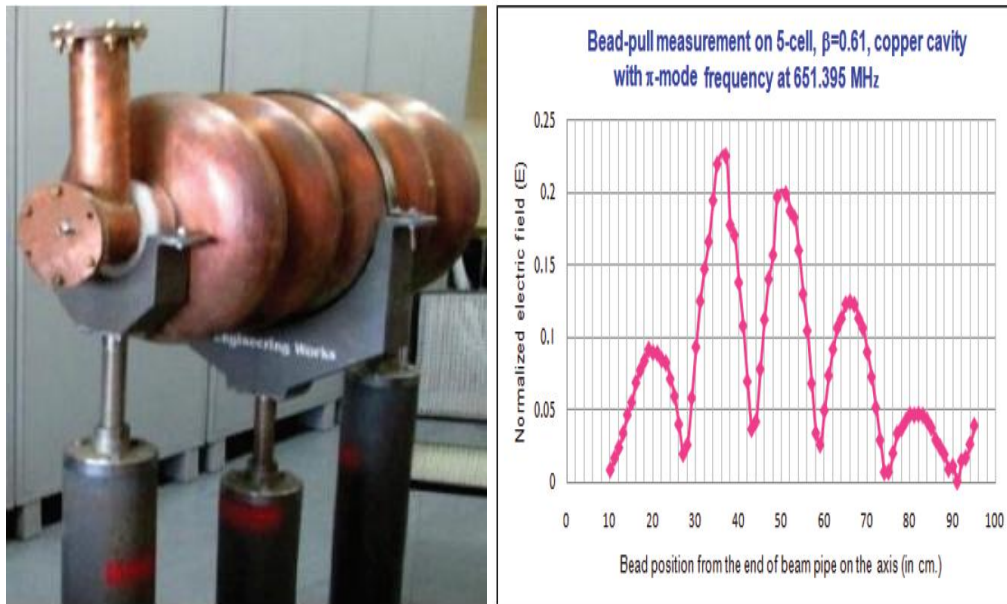

Fig. 14. 5-cell copper prototype cavity and Fig. 15. Measured the E-field profile for π -mode

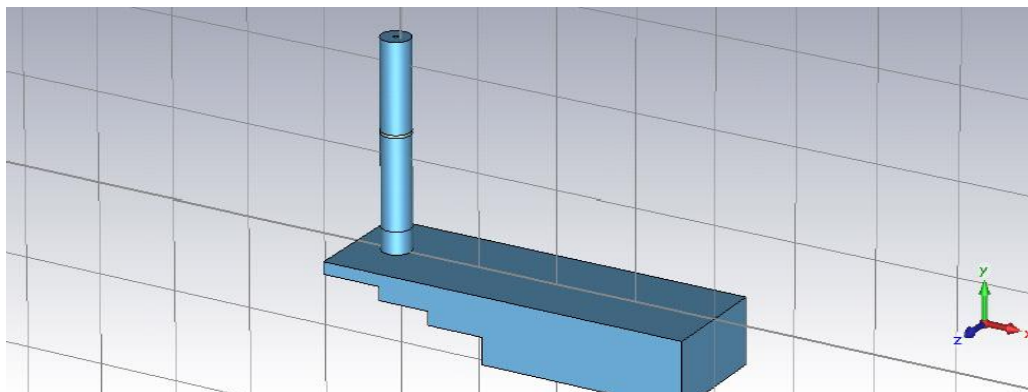

Fig. 16. Final structure after joining Co-axial and Rectangular Waveguide

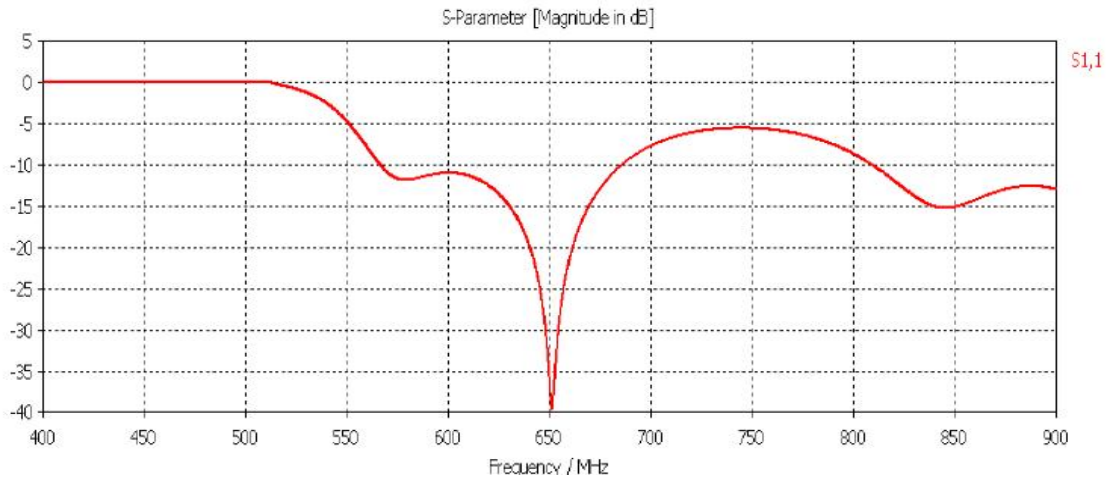

Fig. 17. Final plot of return loss (dB) Vs. Frequency (MHz)

6. CONCLUSION

Several electromagnetic simulations have been performed on the fundamental power coupler of the superconducting RF cavity. The different values of the Reflection coefficient (dB) are noted with the change of dimensions of the coaxial and rectangular waveguide. The operating frequency is 650 MHz. Here we can see that if we increase the inner radius of the co-axial for impedance matching of ceramic, then the peak of Reflection Coefficient is moving towards a higher frequency than 650 MHz. Similarly, if we increase the distance of the higher inner diameter portion from the ceramic window then the peak will move towards lower frequency. Besides this, the reflection coefficient is also changed according to the change of dimensions. The doorknob height and the short location distance have significant influences on the minimum peak of the reflection coefficient as well as on the frequency. If we increase the short location distance then the peak of the reflection coefficient will be shifted towards lower frequency. The power coupler will work more perfectly if the Reflection coefficient is reduced to a value as low as possible.

Cavity shape enhancement of a model five cell superconducting circular cavity has been finished utilizing SUPERFISH code. Trapped higher resonant modes inside the cavity are examined utilizing CST MSW code. An input power coupler has been planned taking preferences of both waveguide and coaxial coupler. We believe that this work will provide a reference for future design of similar high power couplers which

serve to superconducting cavities of high quality factor and high accelerating gradient.

COMPETING INTERESTS

Authors have declared that no competing interests exist.

REFERENCES

- Roy A. et al. Preliminary Design of an RF Superconducting single-cell elliptical cavity for proton linac. INPAC; 2005.
- IPAC' 19 10th International Particle Accelerator Conference proceedings on May 2019 at Melbourne Convention and Exhibition Centre (MCEC) Melbourne, Australia.
- CST Microwave Studio 5.0. Available:www.cst.de
- Padamsee H. RF Superconductivity: Science, Technology and Applications (Wiley-VCH, Weinheim; 2009.
- RF power tests of rf input coupler for the IFMIF/EVEDA RFQ prototype linac, by Maebara et.al.; 2017. DOI: 10.1016/j.fusengdes.2017.03.112
- Campisi IE. Fundamental Power Couplers for Superconducting Cavities. Proceedings of the 10th Workshop on RF Superconductivity, Tsukuba, Japan. 2001;132-143.
- Superconducting Radio-Frequency Cavities by Hasan S. Padamsee, The Annual Review of Nuclear and Particle Science; 2014.

- DOI:10.1146/annurev-nucl-102313-0256129
8. Sudeshna Seth, Sumit Som et.al. Multipacting Analysis on 650MHz beta .61 superconducting RF Linac Cavity, INPAC; 2013.
 9. Electromagnetic Fields Excited in Volumes with Spherical Boundaries by Penkin et al. Springer; 2019.
 10. Huang TM, Pan WM, Ma Q, et al. Nuclear Instruments and Methods in Physics Research. 2010;623:895-902.
 11. Microwave Active Devices and Circuits for Communication, by Subhas Chandra Bera. Springer; 2019.
DOI: 10.1007/978-981-13-3004-9.

© 2020 Das and Biswas; This is an Open Access article distributed under the terms of the Creative Commons Attribution License (<http://creativecommons.org/licenses/by/4.0>), which permits unrestricted use, distribution, and reproduction in any medium, provided the original work is properly cited.

Peer-review history:
The peer review history for this paper can be accessed here:
<http://www.sdiarticle4.com/review-history/62612>